

## User Manual



[www.indesit.com/register](http://www.indesit.com/register)



---

# USER MANUAL

---



## THANK YOU FOR BUYING AN INDESIT PRODUCT.

In order to receive a more complete assistance,  
please register your appliance on [www.indesit.com/register](http://www.indesit.com/register)

---

## INDEX

<b>HEALTH &amp; SAFETY GUIDE.....</b>	<b>3</b>
<b>Safety instructions.....</b>	<b>3</b>
<b>USE &amp; CARE GUIDE .....</b>	<b>5</b>
<b>Product Description .....</b>	<b>5</b>
Control panel .....	5
Refrigerator light.....	6
Shelves .....	6
Door.....	6
<b>How to use the appliance .....</b>	<b>7</b>
First time use .....	7
Refrigerator compartment and food storage .....	7
How to store fresh food and beverage .....	7
Freezer compartment and food storage.....	8
Removing the freezer drawer container.....	8
Tips for freezing and storing fresh food .....	8
Frozen food: shopping tips .....	8
Storage times for home frozen foods .....	9
Defrosting the freezer compartment.....	9
Functional sounds .....	9
Recommendation in case of no use of the appliance .....	10
<b>Cleaning and maintenance .....</b>	<b>10</b>
<b>Troubleshooting.....</b>	<b>11</b>
<b>After-sales service .....</b>	<b>12</b>
<b>INSTALLATION GUIDE.....</b>	<b>13</b>

## SAFETY INSTRUCTIONS

Before using the appliance, read these safety instructions. Keep them nearby for future reference. These instructions and the appliance itself provide important safety warnings, to be observed at all times. The manufacturer declines any liability for failure to observe these safety instructions, for inappropriate use of the appliance or incorrect setting of controls.

⚠ Very young children (0-3 years) should be kept away from the appliance. Young children (3-8 years) should be kept away from the appliance unless continuously supervised. Children from 8 years old and above and persons with reduced physical, sensory or mental capabilities or lack of experience and knowledge can use this appliance only if they are supervised or have been given instructions on safe use and understand the hazards involved. Children must not play with the appliance. Cleaning and user maintenance must not be carried out by children without supervision.

### PERMITTED USE

⚠ CAUTION: The appliance is not intended to be operated by means of an external switching device, such as a timer, or separate remote controlled system.

⚠ This appliance is intended to be used in household and similar applications such as: staff kitchen areas in shops, offices and other working environments; farm houses; by clients in hotels, motels, bed & breakfast and other residential environments.

⚠ This appliance is not for professional use. Do not use the appliance outdoors.

⚠ The bulb used inside the appliance is specifically designed for domestic appliances and is not suitable for general room lighting within the home (EC Regulation 244/2009).

⚠ The appliance is designed for operation in places where the ambient temperature comes within the following ranges, according to the climatic class given on the rating plate. The appliance may not work properly if it is left for a long time at a temperature outside the specified range.

Climatic Class Amb. T. (°C)

SN: From 10 to 32 °C; N: From 16 to 32 °C

ST: From 16 to 38 °C; T: From 16 to 43 °C

⚠ This appliance does not contain CFCs. The refrigerant circuit contains R600a (HC). Appliances with Isobutane (R600a): isobutane is a natural gas without environmental impact, but is flammable. Therefore, make sure the refrigerant circuit pipes are not damaged, especially when emptying the refrigerant circuit.

⚠ WARNING: Do not damage the appliance

## IMPORTANT TO BE READ AND OBSERVED

refrigerant circuit pipes.

⚠ WARNING: Keep ventilation openings, in the appliance enclosure or in the built-in structure, clear of obstruction.

⚠ WARNING: Do not use mechanical, electric or chemical means other than those recommended by the Manufacturer to speed up the defrost process.

⚠ WARNING: Do not use or place electrical devices inside the appliance compartments if they are not of the type expressly authorised by the Manufacturer.

⚠ WARNING: Ice makers and/or water dispensers not directly connected to the water supply must be filled with potable water only.

⚠ WARNING: Automatic ice-makers and/or water dispensers must be connected to a water supply that delivers potable water only, with mains water pressure between 0.17 and 0.81 MPa (1.7 and 8.1 bar).

⚠ Do not store explosive substances such as aerosol cans and do not place or use gasoline or other flammable materials in or near the appliance.

⚠ Do not swallow the contents (non-toxic) of the ice packs (provided with some models). Do not eat ice cubes or ice lollies immediately after taking them out of the freezer since they may cause cold burns.

⚠ For products designed to use an air filter inside an accessible fan cover, the filter must always be in position when the refrigerator is in function.

⚠ Do not store glass containers with liquids in the freezer compartment since they may break.

Do not obstruct the fan (if included) with food items. After placing the food check that the door of the compartments closes properly, especially the freezer door.

⚠ Damaged gaskets must be replaced as soon as possible.

⚠ Use the refrigerator compartment only for storing fresh food and the freezer compartment only for storing frozen food, freezing fresh food and making ice cubes.

⚠ Avoid storing unwrapped food in direct contact with internal surfaces of the refrigerator or freezer compartments.

Appliances could have special compartments (Fresh Food Compartment, Zero Degree Box, etc.). Unless specified in the specific booklet of product, they can be removed, maintaining equivalent performances.

⚠ C-Pentane is used as blowing agent in the insulation foam and it is a flammable gas.

### INSTALLATION

⚠ The appliance must be handled and installed by two or more persons - risk of injury. Use protective gloves to unpack and install - risk of cuts.

⚠ Installation, including water supply (if any) and electrical connections, and repairs must be carried out by a qualified technician. Do not repair or replace any part of the appliance unless specifically stated in the user manual. Keep children away from the installation site. After unpacking the appliance, make sure that it has not been damaged during transport. In the event of problems, contact the dealer or your nearest After-sales Service. Once installed, packaging waste (plastic, styrofoam parts etc.) must be stored out of reach of children - risk of suffocation. The appliance must be disconnected from the power supply before any installation operation - risk of electric shock. During installation, make sure the appliance does not damage the power cable - risk of fire or electric shock. Only activate the appliance when the installation has been completed.

⚠ Be careful not to damage the floors (e.g. parquet) when moving the appliance. Install the appliance on a floor or support strong enough to take its weight and in a place suitable for its size and use. Make sure the appliance is not near a heat source and that the four feet are stable and resting on the floor, adjusting them as required, and check that the appliance is perfectly level using a spirit level. Wait at least two hours before switching the appliance on, to ensure that the refrigerant circuit is fully efficient.

⚠ To guarantee adequate ventilation, leave a space on both sides and above the appliance. The distance between the rear of the appliance and the wall behind the appliance should be 50 mm, to avoid access to hot surfaces. A reduction of this space will increase the Energy consumption of product.

⚠ **WARNING:** To avoid a hazard due to instability, positioning or fixing of the appliance must be done in accordance with the manufacturer instructions. It is forbidden to place the refrigerator in such way that the metal hose of gas stove, metal gas or water pipes, or electrical wires are in contact with the refrigerator back wall (condenser coil).

### **ELECTRICAL WARNINGS**

⚠ It must be possible to disconnect the appliance from the power supply by unplugging it if plug is accessible, or by a multi-pole switch installed upstream of the socket in accordance with the wiring rules and the appliance must be earthed in conformity with national electrical safety standards.

⚠ Do not use extension leads, multiple sockets or adapters. The electrical components must not be accessible to the user after installation. Do not use the appliance when you are wet or barefoot. Do not operate this appliance if it has a damaged power cable or plug, if it is not working properly, or if it has been damaged or dropped.

⚠ If the supply cord is damaged, it must be replaced with an identical one by the manufacturer, its service agent or similarly qualified persons in order to avoid a hazard - risk of electric shock.

### **CLEANING AND MAINTENANCE**

⚠ **WARNING:** Ensure that the appliance is switched off and disconnected from the power supply before performing any maintenance operation; never use steam cleaning equipment - risk of electric shock.

⚠ Do not use abrasive or harsh cleaners such as window sprays, scouring cleansers, flammable fluids, cleaning waxes, concentrated detergents, bleaches or cleansers containing petroleum products on plastic parts, interior and door liners or gaskets. Do not use paper towels, scouring pads, or other harsh cleaning tools.

### **DISPOSAL OF PACKAGING MATERIALS**

The packaging material is 100% recyclable and is marked with the recycle symbol .

The various parts of the packaging must therefore be disposed of responsibly and in full compliance with local authority regulations governing waste disposal.

### **DISPOSAL OF HOUSEHOLD APPLIANCES**

This appliance is manufactured with recyclable or reusable materials. Dispose of it in accordance with local waste disposal regulations. For further information on the treatment, recovery and recycling of household electrical appliances, contact your local authority, the collection service for household waste or the store where you purchased the appliance. This appliance is marked in compliance with European Directive 2012/19/EU, Waste Electrical and Electronic Equipment (WEEE). By ensuring this product is disposed of correctly, you will help prevent negative consequences for the environment and human health.

The symbol  on the product or on the accompanying documentation indicates that it should not be treated as domestic waste but must be taken to an appropriate collection center for the recycling of electrical and electronic equipment.

### **ENERGY SAVING TIPS**

Install the appliance in a dry, well ventilated room far away from any heat source (eg. radiator, cooker, etc.) and in a place not exposed directly to the sun. If required, use an insulating plate.

To guarantee adequate ventilation follow installation instructions. Insufficient ventilation at the back of the product increases energy consumption and decreases cooling efficiency.

Frequent door opening might cause an increase in Energy Consumption. The internal temperature of the appliance and the Energy Consumption may be affected also by the ambient temperature, as well as location of the appliance. Temperature setting should take into consideration these factors.

Reduce door opening to a minimum.

When thawing frozen food, place in the refrigerator. The low temperature of the frozen products cools the food in the refrigerator. Allow warm food and drinks to cool down before placing in the appliance.

Positioning of the shelves in the refrigerator has no impact on the efficient usage of energy. Food should be placed on the shelves in such way to ensure proper air circulation (food should not touch each other and distance between food and rear wall should be kept).

You can increase storage capacity of frozen food by removing baskets and, if present, Stop Frost shelf.

Do not worry about noises coming from the compressor which are described as normal noises in this product's Quick Guide.

## PRODUCT DESCRIPTION

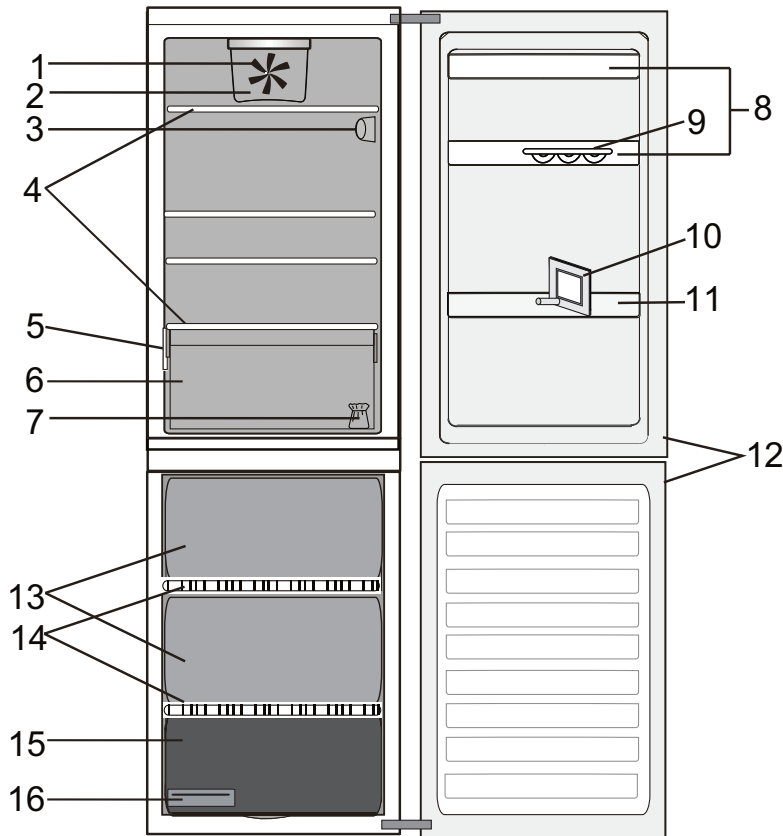

### Refrigerator Compartment

1. Fan\*
2. Fan cover\*
3. Electronic control panel/light unit
4. Shelves
5. Rating plate with commercial name
6. Fruits and vegetables crisper
7. Door reversibility kit
8. Door trays
9. Egg tray\*
10. Bottle separator\*
11. Bottle balcony\*
12. Door seal

### Freezer Compartment

12. Door seals
13. Freezer drawers
14. Shelves
15. Bottom drawer: coolest zone best for freezing fresh food
16. Ice tray\*

\* Available only on certain models

## CONTROL PANEL

### B. Thermostat Knob

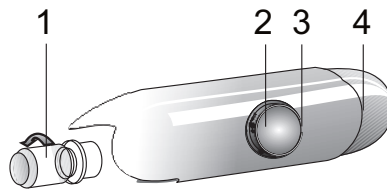

1. Light bulb
2. Thermostat knob
3. Thermostat seating indicator
4. Light button

### FREEZING FRESH FOOD

Place fresh food to be frozen on the shelf in the freezer compartment, avoiding direct contact with food that is already frozen.

The quantity of fresh food that can be frozen in 24 hours is written on the rating plate.

To freeze fresh food, place the freezer compartment shelf in the bottom position.

### FAN\*

The Fan improves temperature distribution inside the refrigerator compartment, allowing better preservation of stored food. By default, the fan is switched on. To turn off the fan press the button of fan. Please note that when the fan is switched on it will not continuously work. The fan will start/stop working depending on the temperature and/or humidity level inside the fridge. It is therefore absolutely normal if the fan does not move even if the fan is switched on. If the appliance has the Fan it can be equipped with the antibacterial filter. Remove it from the box placed in the crisper drawer and insert into the fan cover - as in the picture. The replacement procedure is included in the filter box.

\* Available only on certain models

### ANTIBACTERIAL FILTER\*

Remove it from the box placed in the Fruit and vegetable drawer and insert into the cover of fan. The replacement procedure is included in the filter box. Replace it every 6 months to ensure optimal protection inside your refrigerator. Visit the website page or contact consumer service to purchase the filter.

### FREEZER AND REFRIGERATOR COMPARTMENT TEMPERATURE

This Fridge/Freezer is switched on by means of the thermostat located inside the refrigerator compartment.

The temperature of both compartments is adjusted by turning the thermostat knob.

Thermostat set to **MIN**: low cooling intensity  
 Thermostat set between **MIN** and **MAX**: cooling intensity can be adjusted according to the preferences.  
 Thermostat set to **MAX**: maximum refrigeration intensity.  
*For the best food conservation MED position is recommended.*  
 Thermostat set to •: cooling and lighting off.

Note: Displayed set points correspond to the average temperature throughout the whole refrigerator.

## REFRIGERATOR LIGHT

---

To remove the light bulb turn anticlockwise as shown in the picture: Check the bulb. If necessary unscrew the broken bulb and replace it with a LED bulb of the same type available only

at our After-sales Service Centers or authorized dealers.

**Important:** The refrigerator compartment light switches on when the refrigerator door is opened.

## SHELVES

---

All shelves, flaps and pull-out baskets are removable.

## DOOR

---

### DOOR REVERSIBILITY

Note: The direction of door opening can be changed. If this operation is performed by After-sales Service it is not covered by the warranty.

Follow instruction in **Installation Guide**.

## HOW TO USE THE APPLIANCE

### FIRST TIME USE

Wait at least two hours, after the installation, before connecting the appliance to the power supply. Connect the appliance to the power supply and turn the thermostat knob to switch on the appliance.

After turning the appliance on, you must wait for 4-6 hours for the correct storage temperature to be reached for a normally filled appliance. Position the antibacterial anti-odour filter in the fan as demonstrated in the filter packaging (if available).

### REFRIGERATOR COMPARTMENT AND FOOD STORAGE

The refrigerator compartment allows for the storage of fresh food and drink. The refrigerator compartment defrosts completely automatically. The occasional presence of drops of water on the internal back wall of the compartment is a sign of the automatic defrosting phase. The defrosting water is channelled into a drain and then collected in a container, where it evaporates.

Note: the ambient temperature, how often the doors are opened and the position of the appliance may affect the internal temperatures in the two compartments. Set the temperatures depending on these factors.

In very humid conditions, condensation may form in the refrigerator compartment, especially on the glass shelves.

In this case, it is recommended that you close containers with liquids in (e.g. a pot of stock), wrap up food with a high water content (e.g. vegetables) and turn on the fan, if there is one. All of the drawers, door shelves and shelves can be removed.

#### AIR VENTILATION

The natural circulation of air in the refrigerator compartment results in zones with different temperatures. It is coldest directly above the fruits and vegetables crisper and at the rear wall. It is warmest at the top front of the compartment. Insufficient ventilation results in an increase in energy consumption and reduction of the refrigerating performance.

### HOW TO STORE FRESH FOOD AND BEVERAGE

Foods which give off a large amount ethylene gas (apples, apricots, pears, peaches, avocado, figs, prunes, blueberries, mellons, beans) and those that are sensitive to this gas, such as fruit vegetables and salad, should always be separated or wrapped so as not to reduce the storage life; for example do not store tomatoes together with kiwi fruits or cabbage. Do not store food too close together to enable sufficient air circulation. Use recyclable plastic, metal, aluminum and glass containers and cling film to wrap foods.

If you have a little quantity of food to store in the refrigerator, we recommend to use the shelves above the crisper for fruits and vegetables since this is the coolest area of the compartment. Always use closed containers for liquids and for food that may give off or be tainted by odor or flavor transfer or cover them. To avoid bottles falling over, you can use the bottle holder (available on selected models).

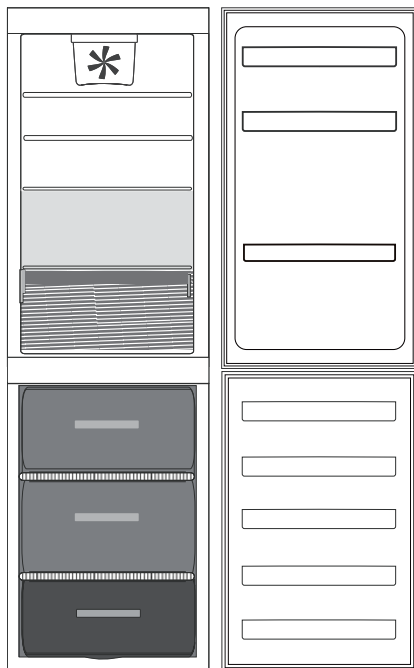

#### Legend

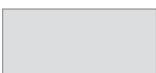
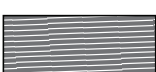
-  **TEMPERATE ZONE**  
Suggested for the storage of tropical fruit, cans, drinks, eggs, sauces, pickles, butter, jam
-  **COOL ZONE**  
Suggested for storage of cheese, milk, dairy food, delicatessen, yogurt
-  **FRUIT & VEGETABLE DRAWER**

## FREEZER COMPARTMENT AND FOOD STORAGE

The freezer compartment  allows for the storage of frozen food (for the period indicated on the packaging) and the freezing of fresh food.

The quantity of fresh food that can be frozen in 24 hours is written on the rating plate.

Arrange the fresh food in the freezing area inside the freezer compartment, leaving enough space around the food packages to allow air to circulate freely. It is advisable that you do not re-freeze food that has partially defrosted. It is important to wrap the food in a way that prevents the ingress of water, humidity or condensation.

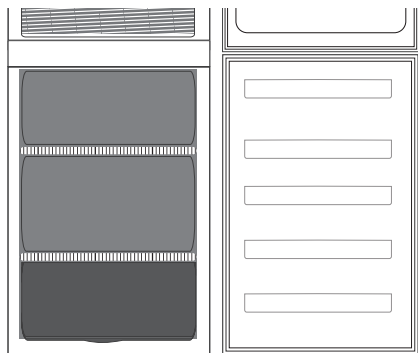

To get more volume, the freezer compartment can be used without the freezer drawers. Make sure that the door is closed properly.

### ICE CUBES

Fill 2/3 of the ice tray with water and put it back in the freezer compartment. Do not use sharp or pointed objects to remove the ice under any circumstances.

### Legend

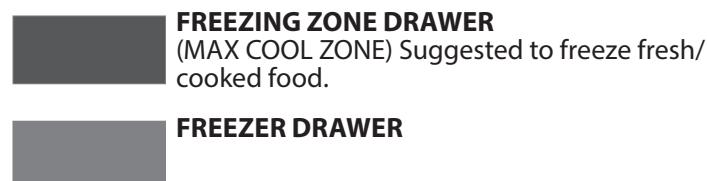

## REMOVING THE FREEZER DRAWER CONTAINER

- Open the freezer door.
- Pull the upper container upwards by the right and left corners (1).
- Remove the drawer (2).
- Install the upper container in the reverse order.

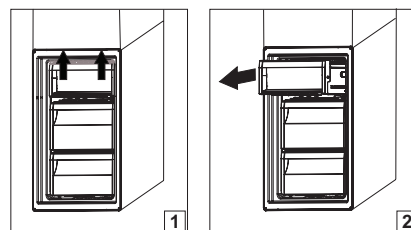

## TIPS FOR FREEZING AND STORING FRESH FOOD

- We recommend to label and date all your frozen food. Adding a label will help you to identify foods and to know when they should be used before their quality deteriorates. Do not re-freeze defrosted food.
- Before freezing, wrap and seal fresh food in: aluminium foil, cling film, air and water-tight plastic bags, polythene containers with lids or freezer containers suitable for freezing fresh food.
- Food must be fresh, mature and of prime quality in order to obtain high quality frozen food.
- Fresh vegetables and fruit should preferably be frozen as soon as they are picked to maintain the full original nutritional value, consistency, colour and flavor. Some meat, especially game, should be hung before it is frozen.
- Always leave hot food to cool before placing in the freezer.
- Eat fully or partially defrosted foods immediately. Do not refreeze unless the food is cooked after it has thawed. Once cooked, the thawed food can be refrozen.
- Do not freeze bottles with liquid.

## FROZEN FOOD: SHOPPING TIPS

When purchasing frozen food products:

- Ensure that the packaging is not damaged (frozen food in damaged packaging may have deteriorated). If the package is swollen or has damp patches, it may not have been stored under optimal conditions and defrosting may have already begun.
- When shopping, buy frozen foods at the end of your trip and transport them in a thermally insulated cool bag.
- Once at home, place the frozen foods immediately in the freezer.
- If food has defrosted even partially, do not refreeze it. Consume within 24 hours.
- Avoid or reduce temperature variations to the minimum. Respect the best-before date on the package.
- Always observe the storage information on the package.



## STORAGE TIMES FOR HOME FROZEN FOODS

Product	Storage period
Butter or margarine	6 months
Cheese	3 months
<b>Fish</b>	2/3 months
Shellfish	1 month
Fruits (except citrus)	8-12 months
Ice cream or sherbet	2/3 months
<b>Meat</b>	
Ham- sausage	2 months
Roasts (beef-pork- lamb)	8/12 months
Steaks or chops (beef-lamb-pork)	4 months
Milk, fresh fluid	1-3 months
Poultry (chicken-turkey)	5- 7 months
Vegetables	8-12 months

## DEFROSTING THE FREEZER COMPARTMENT

The freezer should be defrosted once or twice a year or when excessive frost is present (3 mm thickness). The formation of frost is normal.

The amount and rate at which frost accumulates depends on room conditions and how often the door is open.

To defrost the unit, switch off the product and take out all food.

Leave the freezer door open to allow the frost to melt.

Use the box under the bottom front of the appliance to collect water (shown on the figure).



Clean the inside of the freezer. Rinse and dry thoroughly.

Switch the appliance back on and store the food inside.

## FUNCTIONAL SOUNDS

Sounds coming from your appliances are normal since it has a number of fans and engines to regulate performances that switch on and off automatically.

### SOME OF THE FUNCTIONAL SOUNDS CAN BE REDUCED THROUGH:

- Leveling the appliance and installing it on an even surface.
- Separating and avoiding contact between the appliance and furniture.
- Checking if the internal components are correctly placed.
- Checking if bottles and containers are not in contact with each other.

### SOME OF THE FUNCTIONAL SOUNDS YOU MIGHT HEAR

1. A hissing sound when switching on the appliance for the first time or after a long pause.



2. A gurgling sound when refrigerant fluid enters into the pipes.



3. BRRR sound is from the compressor running.



4. Buzzing sound when water valve or fan start working.



5. A cracking sound when compressor starts.



6. The CLICK is from the thermostat which adjusts how often the compressor is running.



## RECOMMENDATION IN CASE OF NO USE OF THE APPLIANCE

### IN THE EVENT OF NON-USE OF THE APPLIANCE

Disconnect the appliance from the power supply, empty it, defrost it (if necessary) and clean it. Keep the doors slightly ajar to let air circulate inside the compartments. By doing this, you avoid the development of mould and bad odours.

### IN THE EVENT OF AN INTERRUPTION TO THE POWER SUPPLY

Keep the doors closed so the food stays cold for as long as possible. Do not re-freeze food that has partially defrosted. If there is a prolonged power cut, the black out alarm may also activate (in products with electronics).

## CLEANING AND MAINTENANCE

**Before any cleaning or maintenance operation, unplug the appliance from the mains or disconnect the electrical power supply.**

**Never use abrasives. Never clean refrigerator parts with flammable fluids.**

**Do not use steam cleaners.**

**The buttons and control panel display must not be cleaned with alcohol or alcohol-derived substances, but with a dry cloth.**

- Periodically clean the appliance with a cloth and a solution of lukewarm water and neutral detergent specifically for refrigerator interiors.
- Clean the outside of the appliance and the door seal with a damp cloth and dry with a soft cloth.
- Condenser placed in the rear of the appliance should be cleaned regularly using a vacuum cleaner.

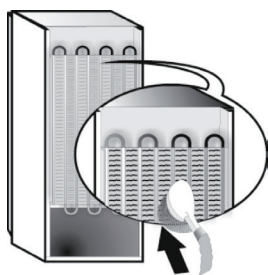

### **Important:**

- The buttons and control panel display must not be cleaned with alcohol or alcohol-derived substances, but with a dry cloth.
- The refrigeration system pipes are located near the defrost pan and can become hot. Periodically clean them with a vacuum cleaner.

To ensure the constant and correct flow of the defrosting water, regularly clean the inside of the drain situated in the back wall of the refrigerator compartment near the fruit and vegetable drawer using the utensil provided.

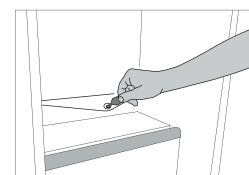

## TROUBLESHOOTING

What to do if...	Possible reasons	Solutions
The appliance is not working.	There may be an appliance power supply problem.	<ul style="list-style-type: none"> <li>• Check if power cable plugged into a live socket with the proper voltage.</li> <li>• Check if the protection devices and fuses of the electrical system in your home</li> </ul>
There is water in the defrost pan.	This is normal in hot, damp weather. The pan can even be half full.	<ul style="list-style-type: none"> <li>• Make sure the appliance is level so that the water does not overflow.</li> </ul>
The edges of the appliance cabinet, which come in contact with the door seal, are warm to the touch.	This is not a defect. This is normal in hot weather and when the compressor is running.	
The light does not work.	The light may need replacing.  The appliance may be in On/Stand-by model.	<ul style="list-style-type: none"> <li>• Make sure if the protection devices and fuses of the electrical system in your home work well.</li> <li>• Check if the power cable is plugged into a live socket with the proper voltage</li> <li>• In case the LEDs are broken the user must call the Service for exchange of the same type available only at our After-sales Service Centers or authorized dealers.</li> </ul>
The motor seems to run too much.	Motor running time depends on different things: number of door openings, amount of food stored, temperature of the room, setting of the temperature controls.	<ul style="list-style-type: none"> <li>• Make sure that the appliance controls are correctly set.</li> <li>• Check if there is not a large amount of food been added to the appliance.</li> <li>• Check that the door is not opened too often.</li> <li>• Check that the door close properly.</li> </ul>
The appliance temperature is too high.	There could be various causes (see "Solutions").	<ul style="list-style-type: none"> <li>• Make sure that the condenser (back the appliance) is free of dust and fluff.</li> <li>• Make sure that the door properly closed.</li> <li>• Make sure that the door seals properly fitted.</li> <li>• On hot days or if the room is warm, the motor naturally runs longer.</li> <li>• If the appliance door has been left open for a while or if large amounts of food have been stored, the motor will run longer in order to cool down the interior of the appliance.</li> </ul>
The doors do not open and close properly.	There could be various causes (see "Solutions").	<ul style="list-style-type: none"> <li>• Check that food packages are not blocking the door.</li> <li>• Check that the internal parts or automatic ice maker are not out of position.</li> <li>• Check that the door seals are not dirty or sticky.</li> <li>• Ensure the appliance is level.</li> </ul>

# AFTER-SALES SERVICE

## BEFORE CALLING THE AFTER-SALES SERVICE

1. See if you can solve the problem by yourself with the help of the suggestions given in the **TROUBLESHOOTING**.
2. Switch the appliance off and back on again to see if the fault persists.

## IF AFTER THE ABOVE CHECKS THE FAULT STILL OCCURS, GET IN TOUCH WITH THE NEAREST AFTER-SALES SERVICE

To receive assistance, call the number shown on the warranty booklet or follow the instructions on the website **www.indesit.com**

When contacting our Client After sales service, always specify:

- a brief description of the fault;
- the type and exact model of the appliance;

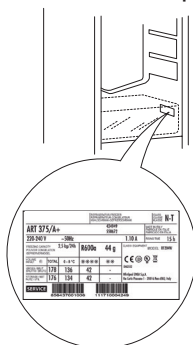

- the service number (number after the word Service on the rating plate). The service number is also indicated on the guarantee booklet;



- your full address;
- your telephone number.

If any repairs are required, please contact an authorised after-sales service (to guarantee that original spare parts will be used and repairs carried out correctly).

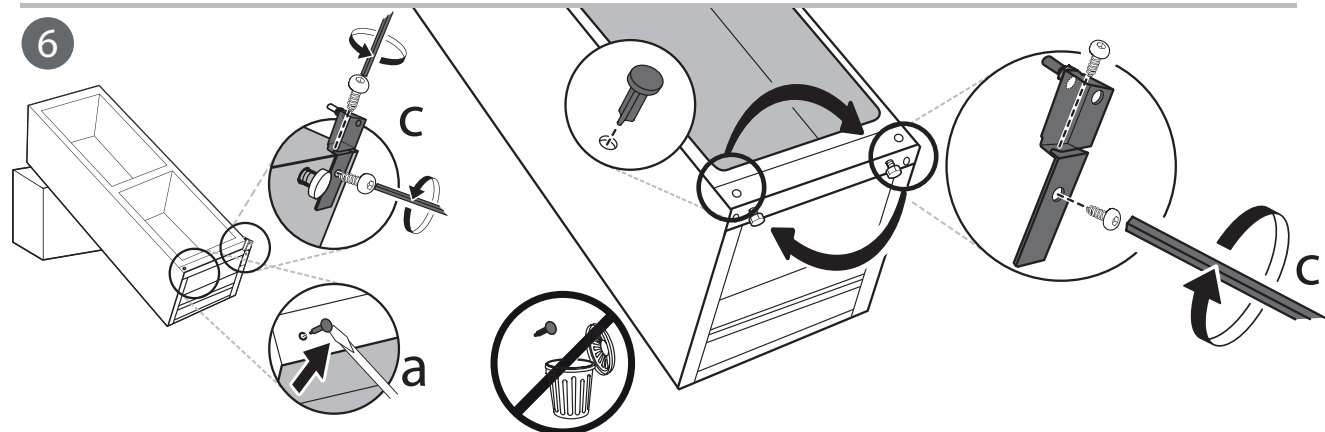
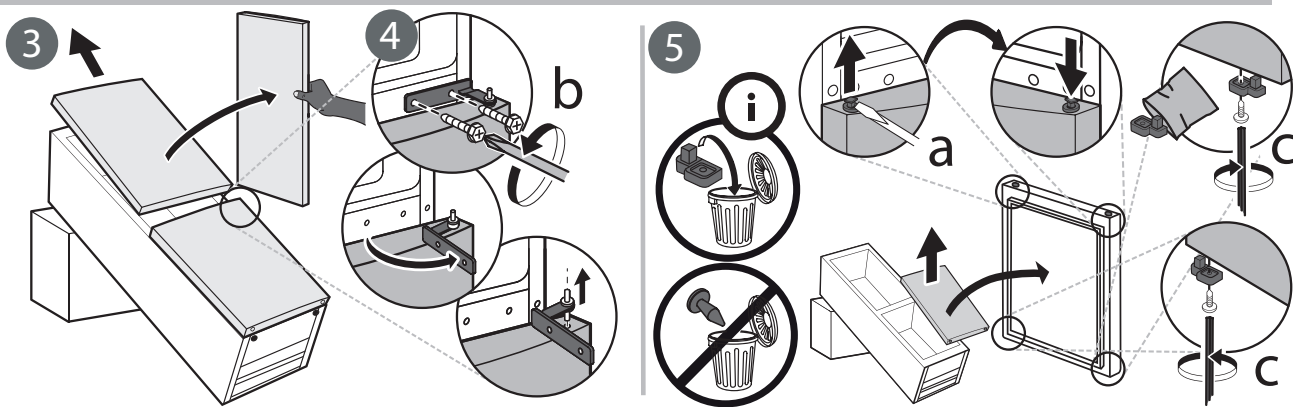
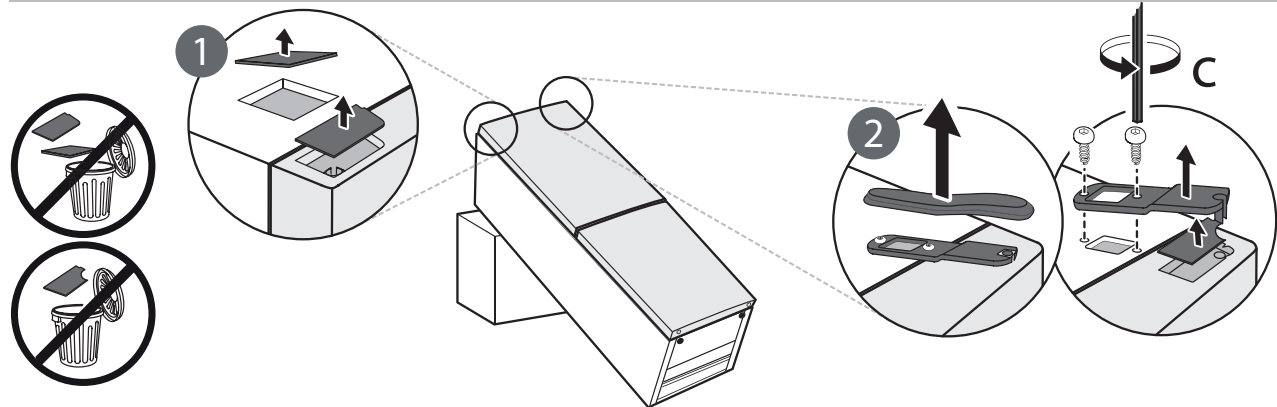
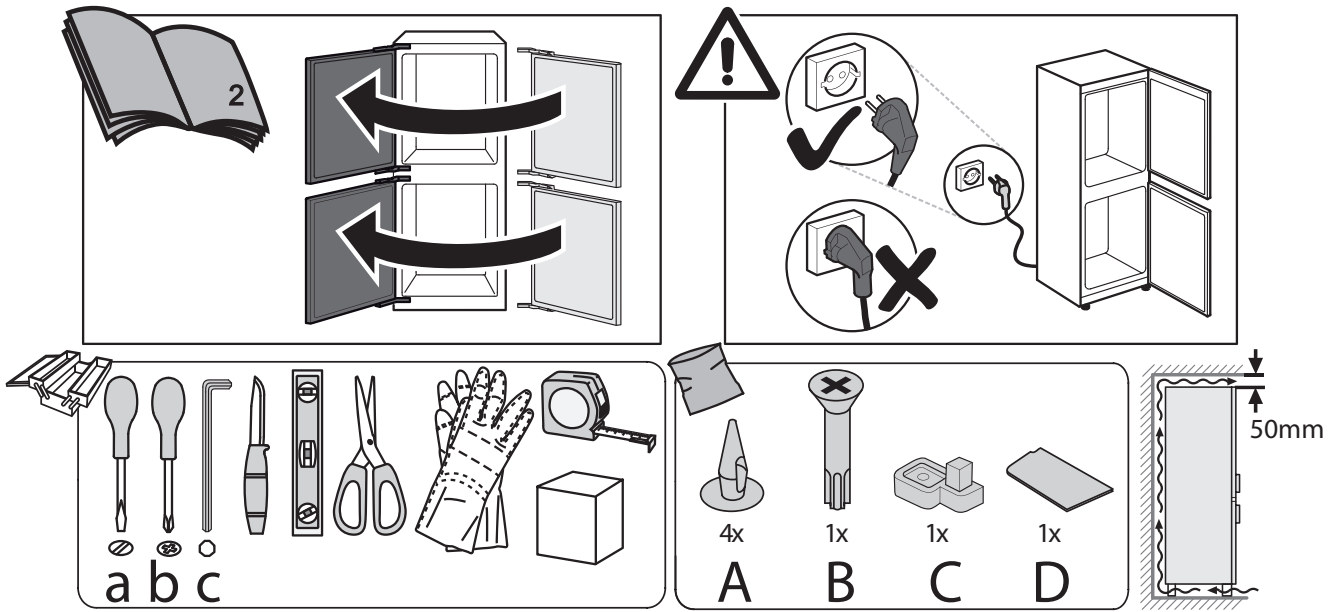

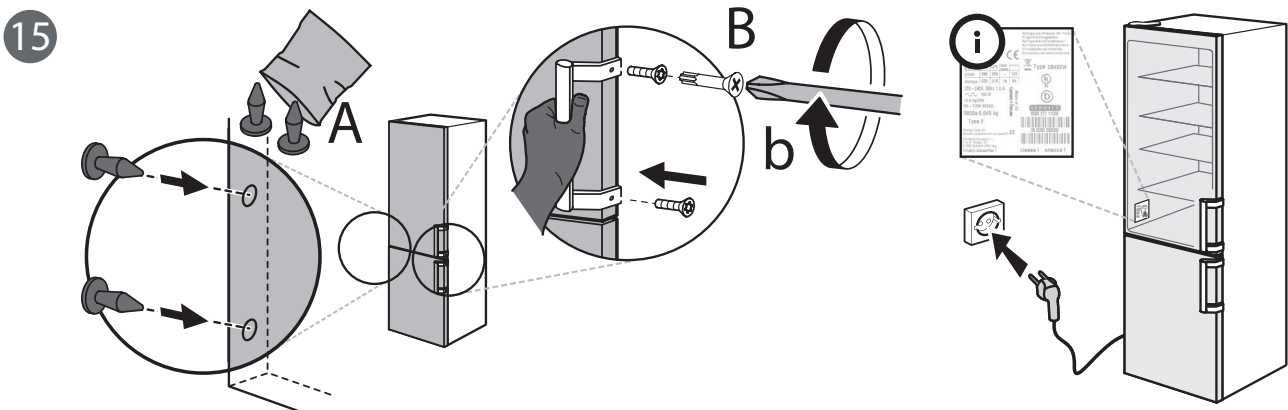
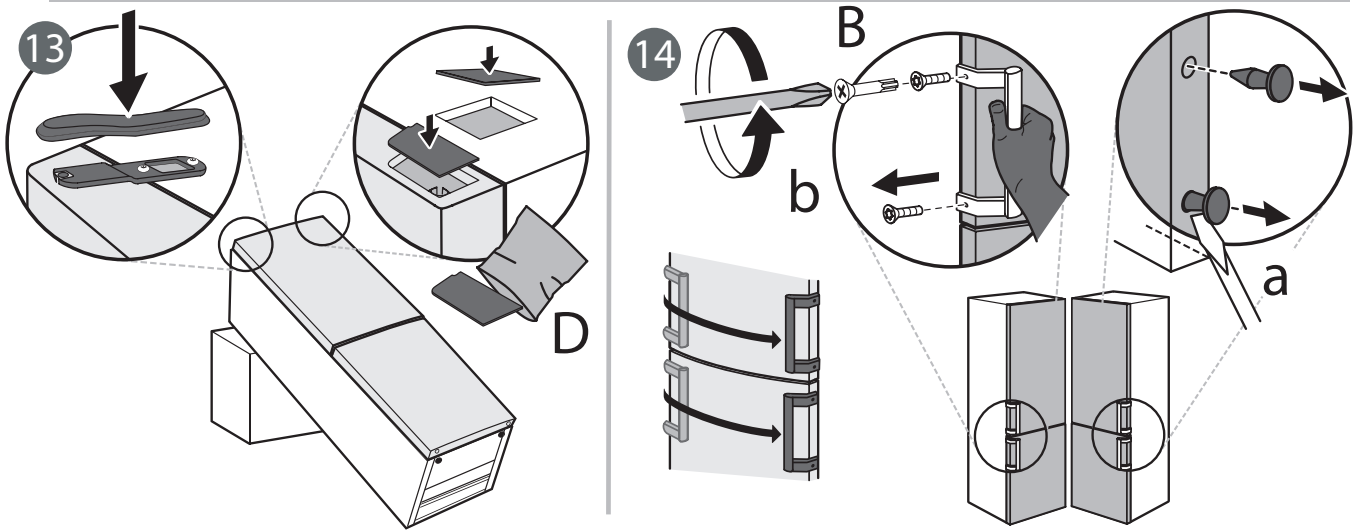
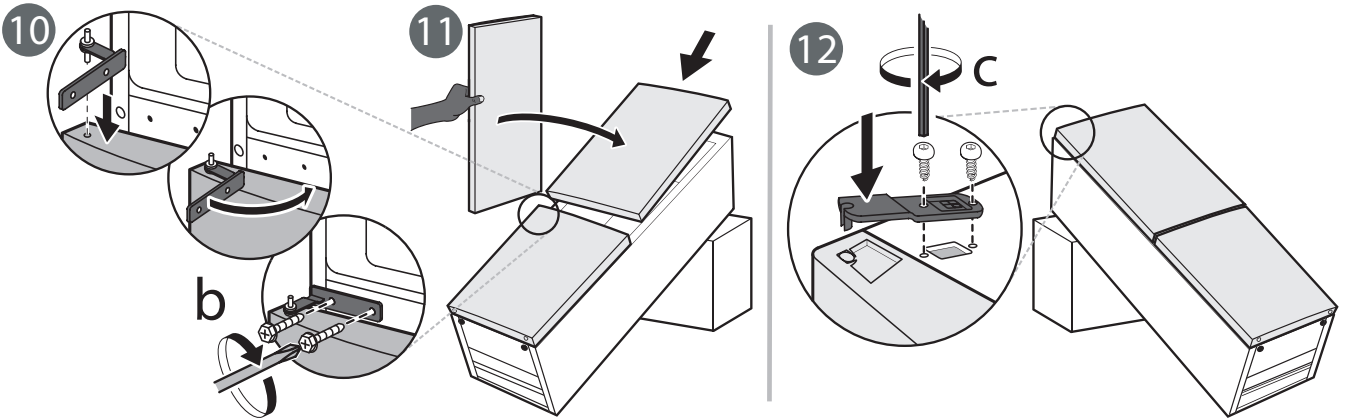
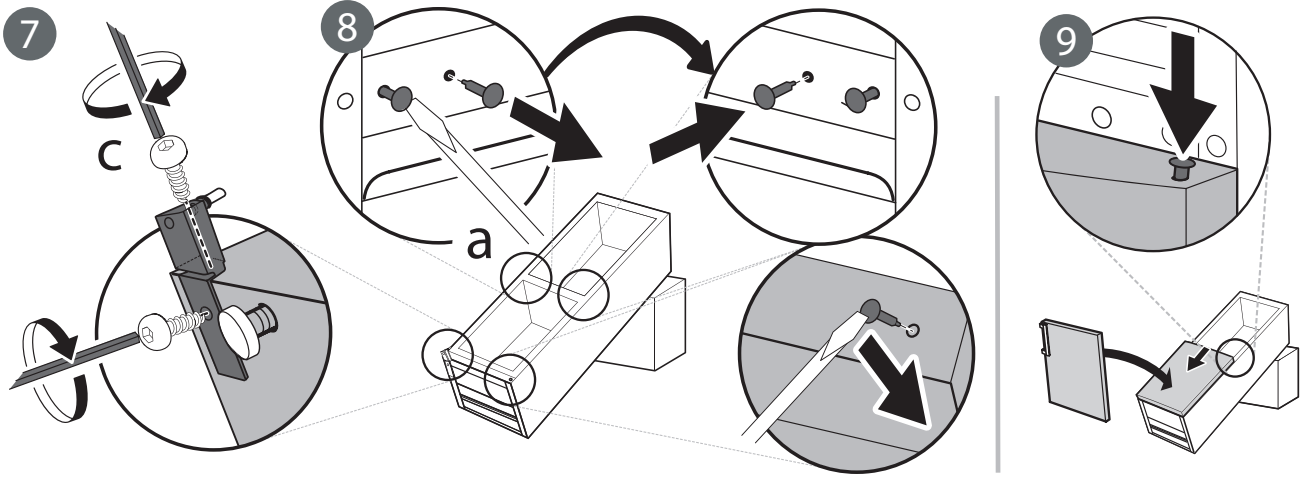

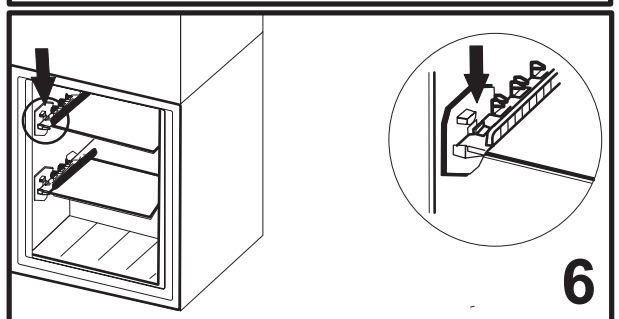
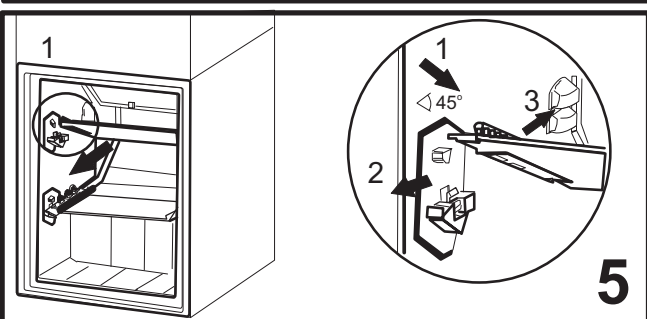
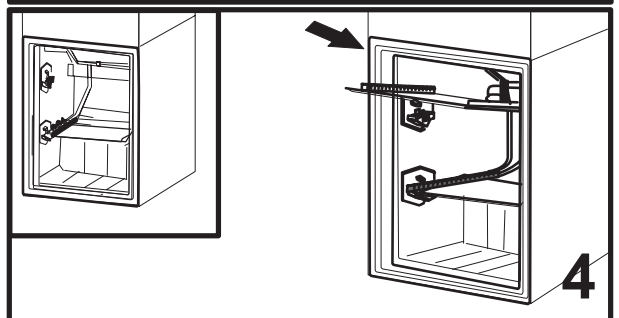
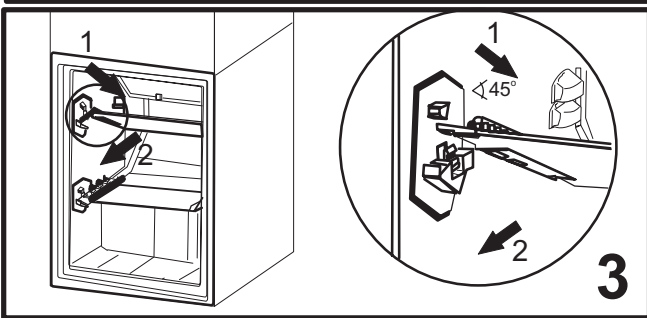
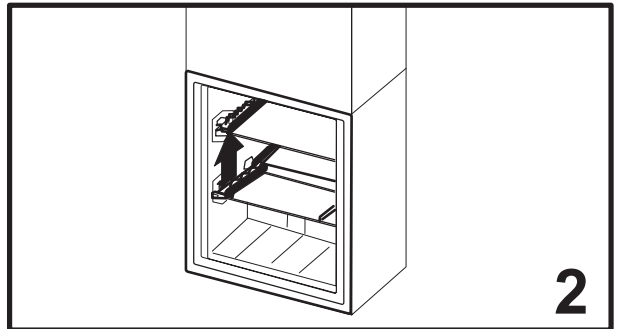
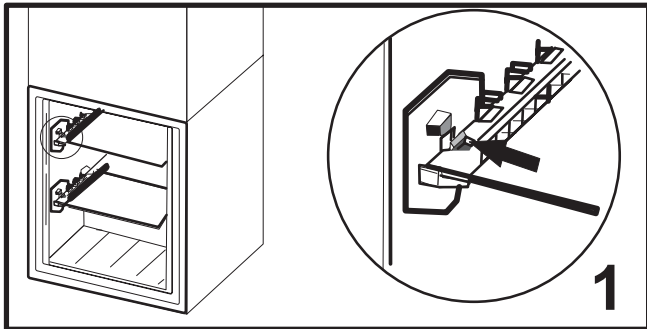
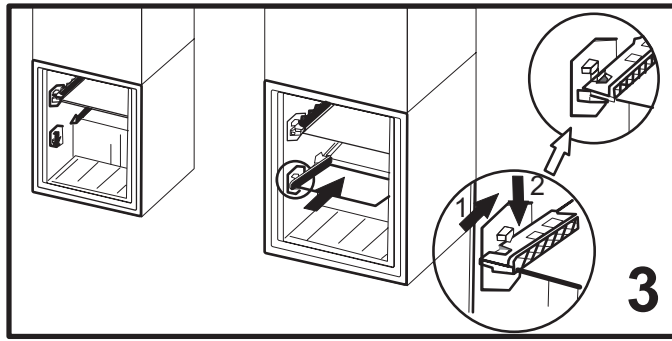
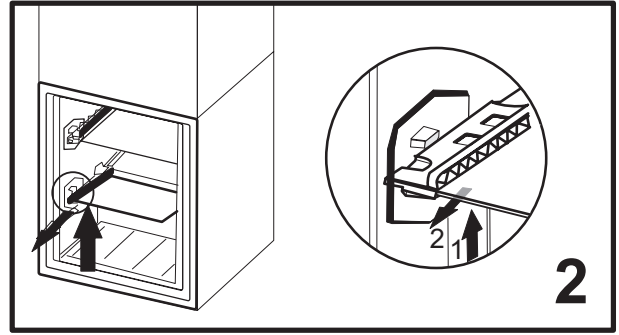
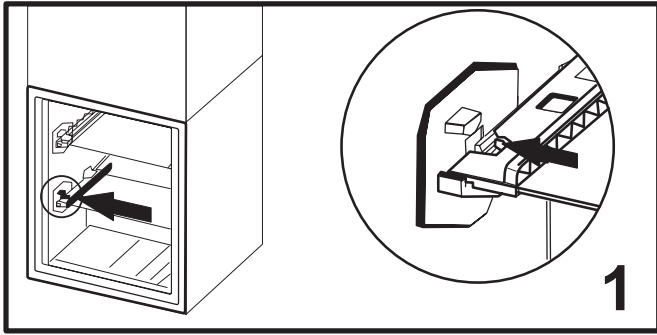

400011046269