

# INSTRUCTIONS FOR USE

## DIAGRAM OF THE APPLIANCE (Fig. 1)

- A. Handle.
- B. Safety lock (if provided).
- C. Gasket.
- D. Separator (if provided).
- E. Defrost water drain plug.
- F. Control panel.
- G. Side motor cooling grille.

## DIAGRAM OF THE CONTROL PANEL (Fig. 2)

1. Temperature adjustment **thermostat**.
2. **Red light** (if provided): indicates that the temperature inside the product is not low enough.
3. **Green LED (if provided)**: when lit, indicates that the appliance is running.
4. **Yellow/orange illuminated button (if provided)**: activates/deactivates the fast freeze function.

When lit, it indicates that the fast freeze function is active.

**The exact configuration of the control panel may vary according to the model.**

## INSTALLATION

- **Unpack the appliance.**
- **Remove the 4 spacers inserted between the door and the appliance. (Fig 3)**
- Make sure the defrost water drain plug (if provided) is correctly positioned (E).
- For optimum appliance operation and to avoid damage when the door is opened, leave a space of at least 7 cm from the rear wall and 7 cm at the sides. **(Fig. 4)**
- Fit the accessories (if provided).
- Clean the inside of the appliance before using it.

## SWITCHING ON THE APPLIANCE

- The appliance is factory set for optimum operation at a temperature of -18°C.
- Plug in the appliance.
- The green LED lights up (if provided).
- Also the red LED (if provided) will switch on because the temperature inside the appliance is not yet sufficiently low for food storage. The red LED will normally switch off within the first six hours after the appliance is switched on.
- After connecting the appliance to the mains supply and when the optimal temperature has been reached, ensure that the fast freeze button is not pressed (the yellow LED, if provided, is off).
- Place food inside the product only when the red LED (if provided) has switched off.

Note: As the seal is tight, the appliance lid cannot be reopened immediately after closing. Wait a few minutes before re-opening the lid of the appliance.

- **This appliance features “skin condenser” technology: the condensing unit is integrated into the walls of the freezer. For this reason the side and front walls of the product may become hot while the product is running. This is entirely normal and also reduces the risk of condensation forming in particularly critical environmental conditions (see paragraph “Troubleshooting guide”).**

## TEMPERATURE ADJUSTMENT

Use the thermostat to select the ideal storage temperature.

To adjust the internal temperature, proceed as follows:

- Turn the thermostat knob to 1 for a storage temperature that is less cold.
- Turn the thermostat knob to 6 for a colder storage temperature.
- For partial loads, or when the load indicator is below the “e” symbol inside the appliance (if present), it is advisable to move the thermostat to the lower position (on “e”, if present on the thermostat scale)

## FREEZING FOOD

### Preparation of fresh food for freezing

- Before freezing, wrap and seal fresh food in: aluminium foil, cling film, air and water-tight plastic bags, polyethylene containers with lids, provided they are suitable for freezing foods.
- Food must be fresh, mature and of prime quality in order to obtain high quality frozen food.
- Fresh vegetables and fruit should preferably be frozen as soon as they are picked to maintain the full original nutritional value, consistency, colour and flavour.
- Always leave hot food to cool before placing in the appliance.

### Freezing fresh food

- Place foods to be frozen in direct contact with the walls of appliance (Fig. 5):

A) - foods to be frozen,

B) - foods already frozen.

- Avoid placing foods to be frozen in direct contact with food already frozen.
  - For best and fastest freezing, foods should be split into small portions; this will also be useful when the frozen items are to be used.
1. At least 24 hours before storing fresh food in the appliance, press the fast freeze button (4).
  2. Place the food to be frozen and keep the lid of the appliance closed for 24 hours. At the end of this period, switch off the fast freeze button (if provided).

## FOOD STORAGE

**Refer to the table on the appliance.**

### Classification of frozen foods

Load and classify the frozen foods; it is advisable to indicate the storage date on the packs, to ensure consumption before the expiry dates listed in months in Fig. 6 for each type of food.

### Advice for storing frozen food

When buying frozen food, make sure that:

- The packaging is intact (food in damaged containers may have deteriorated). If a package is swollen or has damp patches, the product may not have been stored in optimum conditions and therefore undergone partial defrosting.
- When shopping, leave frozen food purchases until last and carry them in a thermally insulated bag.
- On arriving home, immediately place the frozen food in the appliance.
- Avoid or minimise temperature variations. Observe the expiry date on the packaging.

- Always follow the storage instructions on frozen food packages.

**Note:**

- **Eat fully or partially defrosted foods immediately. Do not refreeze unless the food is cooked after it has thawed. Once cooked, the food can be refrozen.**
- **In case of a prolonged power failure: Do not open the appliance door, except to place ice packs (if provided) over the frozen foods on the right and left side of the appliance. This will slow down the rise in temperature.**

**APPLIANCE DEFROSTING**

The appliance should be defrosted when the thickness of ice on the walls reaches 5-6 mm.

- Disconnect the appliance from the power supply.
- Remove food from the appliance and put it in a very cool place or a thermally insulated bag.
- Leave the appliance door open.
- Remove the internal defrost water drain plug (depending on model) (Fig. 8).
- Remove the external defrost water drain plug (depending on model) and reposition it as shown in fig. 8.
- Use the separator (depending on model) inside the product as a recipient for any remaining water, (D) as shown in fig. 8. If there is no separator, use a shallow container.
- Defrosting can be sped up by using a spatula to detach the frost from the appliance walls.
- Remove the frost from the bottom of the appliance.
- **In order to avoid permanent damage to the appliance interior, do not use pointed or sharp metal instruments to remove the ice.**
- **Do not use abrasive products or heat up the interior artificially.**
- **Dry the inside of the appliance thoroughly.**
- Refit the plug after defrosting.

**HANGING THE LID LIGHT BULB (if provided)**

- Disconnect the appliance from the mains power supply.
- Remove the diffuser by following the sequence of steps shown in the figure.
- Unscrew the light bulb and replace it with an identical bulb of the same wattage and voltage.
- Refit the diffuser and plug in the appliance.

**TROUBLESHOOTING GUIDE**

**1. The red LED (if provided) remains alight.**

- Is there a power failure?
- Is defrosting in progress?
- Is the appliance lid properly closed?
- Is the appliance positioned near a heat source?
- Is the thermostat setting correct?
- Are the ventilation grille and condenser clean?

**2. The appliance is too noisy.**

- Is the appliance perfectly horizontal?
- Is the appliance in contact with other furniture or objects that may cause vibrations?
- Has the packaging been removed from under the appliance?

**Note:** Gurgling noises from the refrigerating circuit after the compressor cuts out are perfectly normal.

**3. The green LED (if provided) is off and the appliance is not working.**

- Is there a power failure?
- Is the plug properly inserted in the socket?
- Is the electric cable intact?

**4. The green LED (if provided) is off and the appliance is working.**

- The green LED is not working. Contact the After Sales Service for a replacement.

**5. The compressor runs continuously.**

- Have hot foods been put in the appliance?
- Has the appliance lid been left open for a long time?
- Is the appliance positioned in a very warm room or near heat sources?
- Is the thermostat setting correct?
- Has the fast freeze function (depending on model) been pressed by mistake?

**6. Too much ice on the upper edge.**

- Are the defrost water drainage plugs correctly positioned?
- Is the appliance lid properly closed?
- Is the appliance lid seal damaged or deformed? (See chapter "Installation")
- Have the 4 protection pieces been removed? (See chapter "Installation")

**7. Condensation forms on the external walls of the appliance**

- It is normal for condensation to form under certain atmospheric conditions (humidity above 85%) or if the appliance is located in a damp or poorly ventilated room.

The performance of the appliance is in no way affected.

**8. The layer of ice on the internal walls of the appliance is not uniform.**

- This phenomenon is quite normal.

**AFTER-SALES SERVICE**

**Before contacting After-Sales Service:**

1. See if you can solve the problem yourself.
2. Switch the appliance on again to see if the problem has been solved. If it has not, disconnect the appliance from the power supply and wait for about an hour before switching on again.
3. If the problem persists after this course of action, contact After-Sales Service.

**Specify:**

- the nature of the fault,
- the model,
- the service number (the number after the word SERVICE on the rating plate on the rear of the appliance),
- your full address,
- your telephone number and area code.

**SERVICE** 0000 000 00000



## ELECTRICAL CONNECTION FOR GREAT BRITAIN AND IRELAND ONLY

**Warning – this appliance must be earthed.**

### Fuse replacement

If the mains lead of this appliance is fitted with a BS 1363A 13amp fused plug, to change a fuse in this type of plug use an A.S.T.A. approved fuse to BS 1362 type and proceed as follows:

1. Remove the fuse cover (A) and fuse (B).
2. Fit replacement 13A fuse into fuse cover.
3. Refit both into plug.

### Important:

The fuse cover must be refitted when changing a fuse and if the fuse cover is lost the plug must not be used until a correct replacement is fitted. Correct replacement are identified by the colour insert or the colour embossed in words on the base of the plug.

Replacement fuse covers are available from your local electrical store.

### For the Republic of Ireland only

The information given in respect of Great Britain will frequently apply, but a third type of plug and socket is also used, the 2-pin, side earth type.

### Socket outlet / plug (valid for both countries)

If the fitted plug is not suitable for your socket outlet, please contact After-sales Service for further instruction.

Please do not attempt to change plug yourself. This procedure needs to be carried out by a qualified technician in compliance with the manufactures instructions and current standard safety regulations.

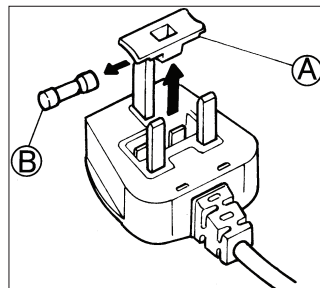

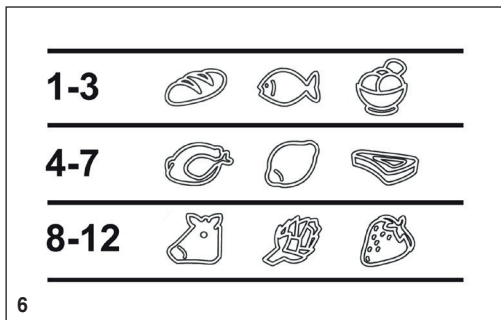
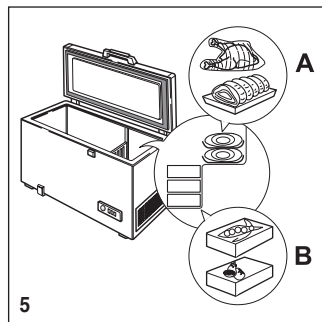
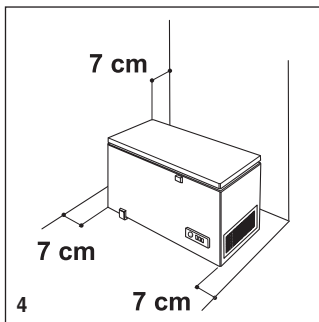
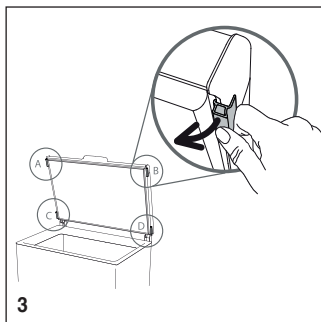
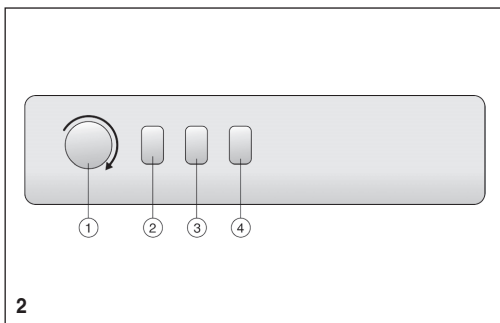
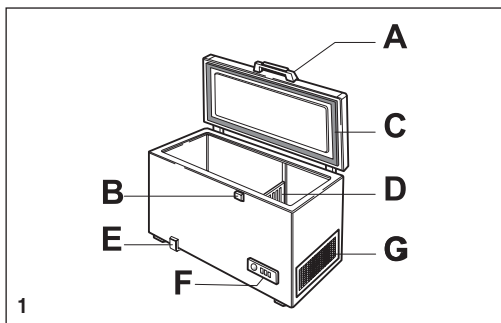

|                                 |       |          |       |
|---------------------------------|-------|----------|-------|
| CLASE / KLASSE / CLASSE / CLASS |       |          |       |
| XXXXX                           |       | XXXXXXXX |       |
| TYP                             | XXXXX | MODEL    | XXXXX |

| CLASE/KLASSE<br>CLASSE/CLASS | °C      | °F       |
|------------------------------|---------|----------|
| SN                           | 10 - 32 | 50 - 90  |
| N                            | 16 - 32 | 61 - 90  |
| ST                           | 16 - 38 | 61 - 100 |
| T                            | 16 - 43 | 61 - 110 |

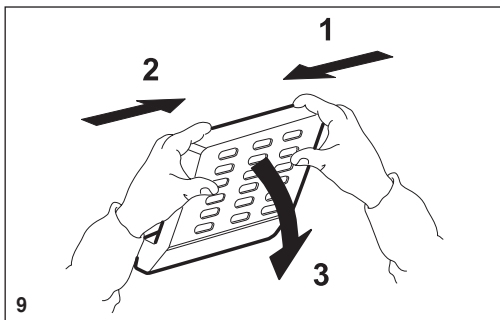
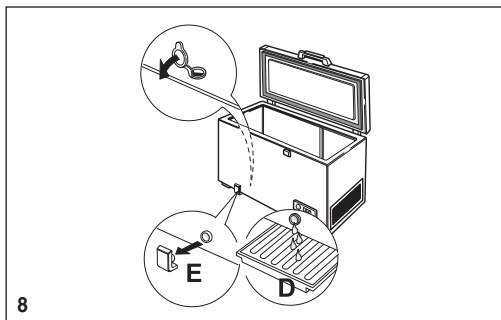

400011232450